

Multimodal representations in student learning of optics: An interdisciplinary representational construction approach

Lihua Xu, Christopher Speldewinde, and Vaughan Prain

School of Education

Deakin University



Australian Research Council Project: Interdisciplinary Maths and Science Learning



ims
LEARNING

Interdisciplinary Maths and Science Learning

Home

Overview

Profiles

Findings

Publications

Resources

Project

Logout



ENRICHING MATHS AND SCIENCE LEARNING: AN INTERDISCIPLINARY APPROACH

This is an international, longitudinal project which aims to investigate the effectiveness of an innovative interdisciplinary learning approach in mathematics and science. Through collaborating primary schools in Australia and the United States of America (USA), it will investigate how students' invention and transformation of representational systems can connect to support deeper reasoning and learning. The project will form the bases for new curricular designs that leverage students' representational practices across science, technology, engineering and mathematics (STEM) disciplines to promote more robust and generative knowledge.

“

Science and Maths are like colours

You mix them together
and you get something
else that's really good, but
it's sort of still the same.

Year 1 student

<https://imslearning.org/>

Key features of the IMS project



1. Aim to deepen learning through the linking of science and mathematics
2. Collaborative planning and exploration with teachers
3. The common features of the sequences – representation construction and mathematical modelling. Opportunities for student creativity, imagination.
4. Pedagogy – guided inquiry featuring co-construction, collaborative and peer learning with opportunities for inventing, reviewing and refining representations and data.
5. Following children longitudinally to investigate cumulative gain

Representation construction and Modeling as interdisciplinary practices



An extensive body of research in science education has been concerned with how students learn **from canonical representations of scientific models** presented in textbooks or **from representations of analogical models** used in classrooms to teach these scientific models (Gilbert & Boulter, 1993; Harrison and Treagust, 2000).

Recent focus on **student generated representations** (e.g. drawings) draws our attention to the role of representations in facilitating student conceptual understanding and supporting student participating in scientific practices such as argumentation (Prain, Tytler, & Peterson, 2009; Prain & Tytler, 2012; Tang, Won, & Treagust, 2019; Tytler et al. 2020).

Science is fundamentally **a modeling enterprise**: (1) students recruit mathematical resources to develop, test, and revise models of the natural world, and (2) students construct, organise and explore data to develop empirical conclusions as products of inquiry (Lehrer & Schauble, 2018; in press).

Research Questions



How do representations in science and mathematics intersect to support student explanations for the phenomenon of light reflection?

What were the challenges and complexities encountered by the teacher and the students as they engaged with this interdisciplinary representation construction approach?

Design Research in Education (Cobb, *et al.*, 2003)



- Working with teachers: Notes of planning meetings, team discussions
- Video capture of case study teacher and field notes and student work samples from all classes
- Drawing on theory to discuss, debate, refine the stages and variations within these that teachers followed
- Encapsulating the pedagogy into 4 key stages, informed by our theoretical perspective

IMS Pedagogy

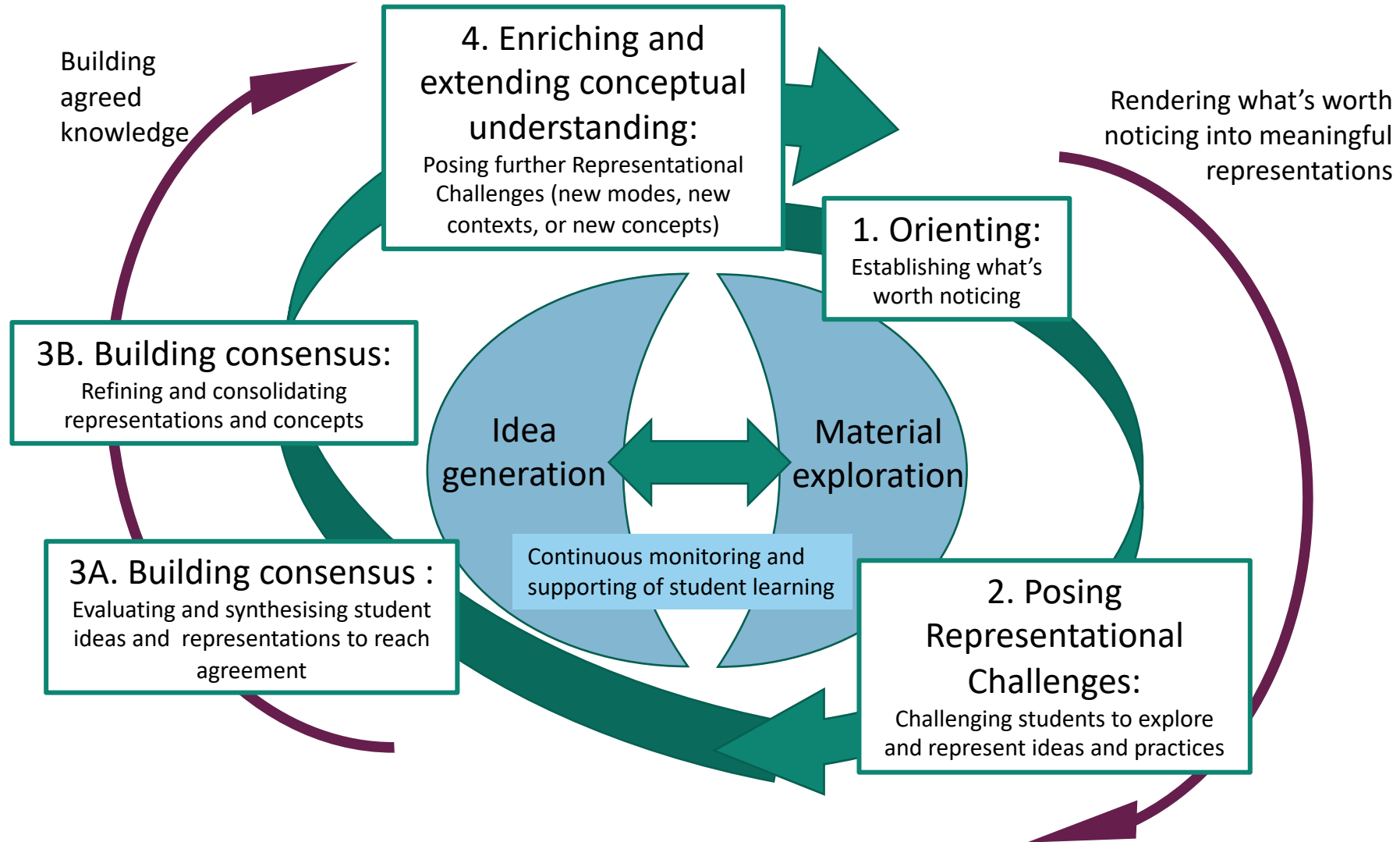

An interdisciplinary unit of work: optics

Lesson focus	Science concepts	Mathematics concepts
Lesson 1 Pre-test and Light spectrum	<ul style="list-style-type: none"> • Path of light • Light spectrum • Reflection • Refraction 	<ul style="list-style-type: none"> • Angles • Lengths • Shapes of prisms
Lesson 2 Shadows	<ul style="list-style-type: none"> • Shadows 	<ul style="list-style-type: none"> • Construct displays, including column graphs, dot plots and tables • Enlargement of shapes • Angle and length of shadow • Identify patterns in data
Lesson 3 Transparent, translucent, opaque	<ul style="list-style-type: none"> • Transparent • Translucent • Opaque 	<ul style="list-style-type: none"> • Construct displays, including column graphs, dot plots and tables • Formal and Informal measurement
Lesson 4 Reflections 1	<ul style="list-style-type: none"> • Reflection 	<ul style="list-style-type: none"> • Describe translations, reflections and rotations of two-dimensional shapes. • Identify line and rotational symmetries • Estimate, measure and compare angles using degrees. • Construct angles using a protractor
Lesson 5 Reflections 2	<ul style="list-style-type: none"> • Reflection 	<ul style="list-style-type: none"> • Describe translations, reflections and rotations of two-dimensional shapes. • Identify line and rotational symmetries • Estimate, measure and compare angles using degrees. • Construct angles using a protractor
Lesson 6 Periscope challenge 1	<ul style="list-style-type: none"> • Reflection 	<ul style="list-style-type: none"> • Construct angles using a protractor
Lesson 7 Periscope challenge 2	<ul style="list-style-type: none"> • Reflection 	<ul style="list-style-type: none"> • Construct angles using a protractor
Lesson 8 Refraction	<ul style="list-style-type: none"> • Refraction 	<ul style="list-style-type: none"> • Describe translations, reflections and rotations of two-dimensional shapes. • Identify line and rotational symmetries
Lesson 9 Refraction and magnification	<ul style="list-style-type: none"> • Refraction 	<ul style="list-style-type: none"> • Apply the enlargement transformation to familiar two-dimensional shapes
Lesson 10 Fun with light	<ul style="list-style-type: none"> • Reflection • Refraction 	<ul style="list-style-type: none"> • Describe translations, reflections and rotations of two-dimensional shapes. • Identify line and rotational symmetries

Preliminary Data Analysis

- Student work
- Student interviews
- Teacher interviews



DEAKIN
UNIVERSITY

Analytical framework for student generated representations

	Descriptive	Explanatory
Not evident	No evidence of understanding of how light behaves.	No explanation of how light travels and facilitates seeing.
Beginning	Limited descriptions of how light behaves using drawings, diagrams, and words.	Limited explanations for how light, object and eyes facilitate seeing.
Developing	Some descriptions of how light behaves using drawings, diagrams and words.	Partial explanations for how light, object and eyes facilitate seeing. Direction of light travelling from object to eyes not made explicit.
Consolidating	Detailed descriptions of how light travels through different media, using drawings, diagrams, and words.	Full explanations for the object-eyes-light relationship.

Reflection: Beginning

When you have one mirror
you can see 1 of the reflection
but when you have two mirrors
faced to each other it will keep having
the same effect on the mirrors.
It will keep reflecting.

diagram

there were
4 lego
reflections
90°

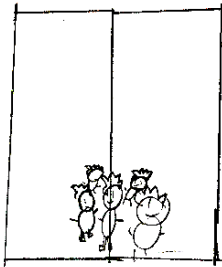

Reflection

I think we saw what we saw because
the mirrors were facing each other so it
kept reflecting over and over again until
the angle got too big so that ~~anything~~ no
light could get through.

side view

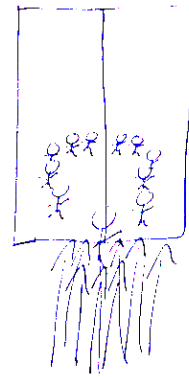
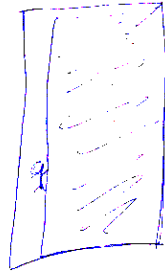

The 30° angle had more room and ~~each~~
the lego man wasn't in there you could see
the reflection of the mirror the light
hits the lego man and it reflected

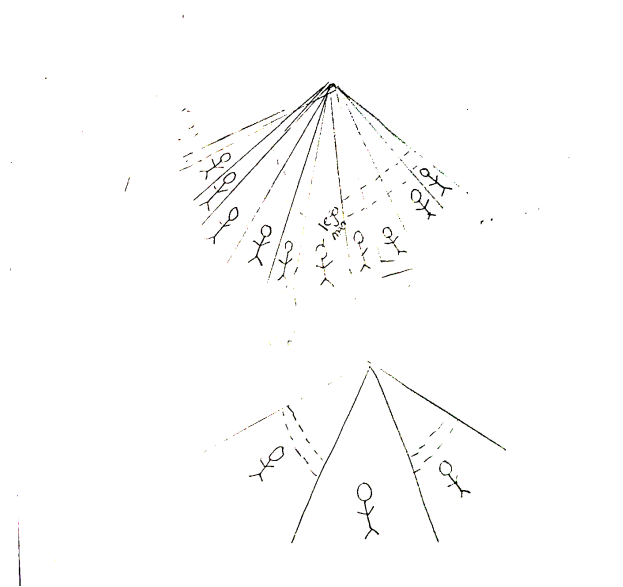

Beginning

Limited descriptions of how light behaves
using drawings, diagrams, and words.

Limited explanations for how light, object and
eyes facilitate seeing.

Reflection: Developing

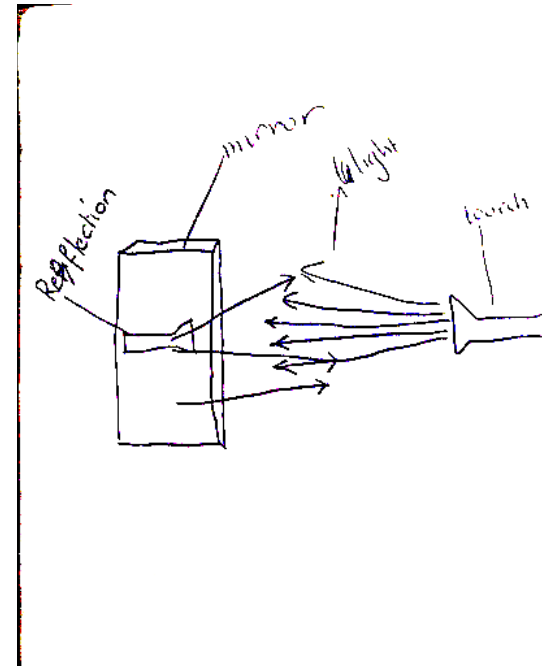
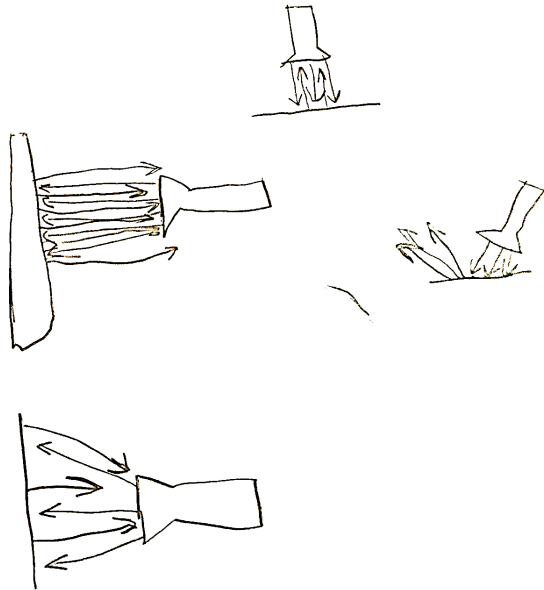

Developing

Some descriptions of how light behaves using drawings, diagrams and words.

Partial explanations for how light, object and eyes facilitate seeing. Direction of light travelling from object to eyes not made explicit.

Reflection: Consolidating

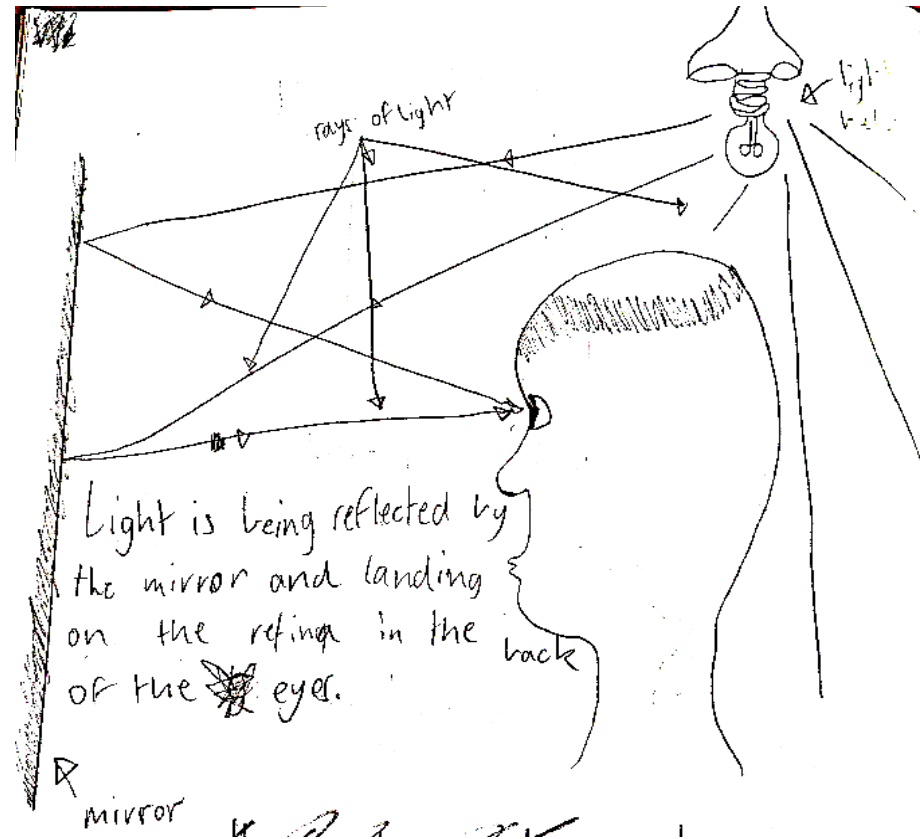

Consolidating

Detailed descriptions of how light travels through different media, using drawings, diagrams, and words.

Full explanations for the object-eyes-light relationship.

Periscope: Beginning

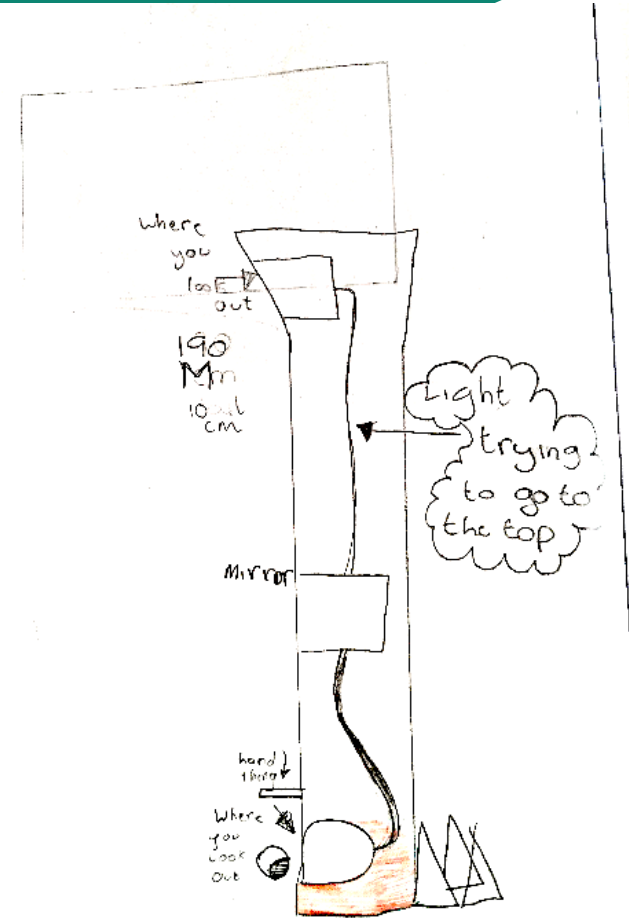
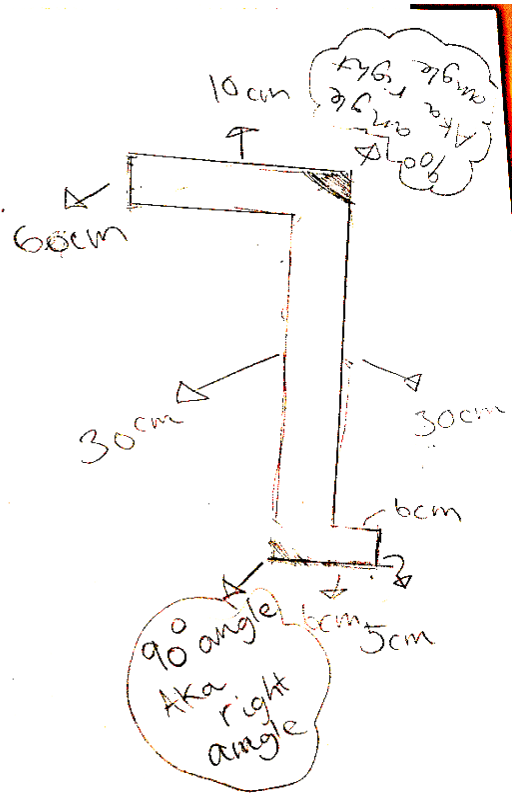

Beginning	Limited descriptions of how light behaves using drawings, diagrams, and words.	Limited explanations for how light, object and eyes facilitate seeing.
-----------	--	--

Periscope: Developing

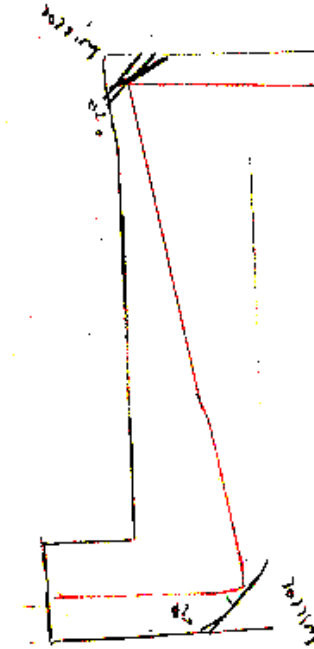
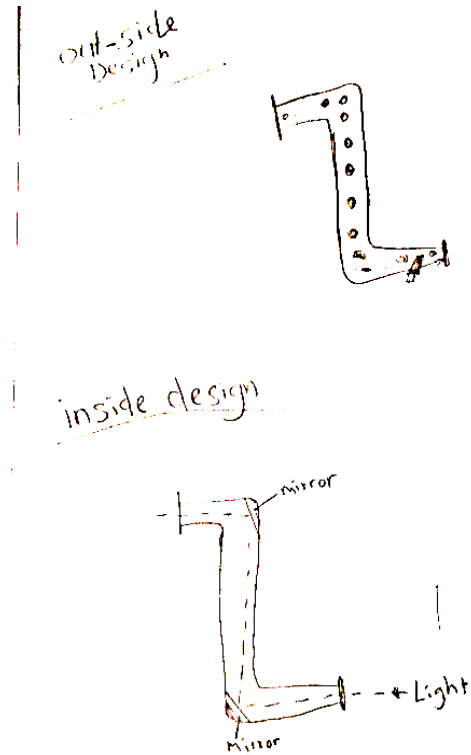

Developing

Some descriptions of how light behaves using drawings, diagrams and words.

Partial explanations for how light, object and eyes facilitate seeing. Direction of light travelling from object to eyes not made explicit.

Periscope: Consolidating

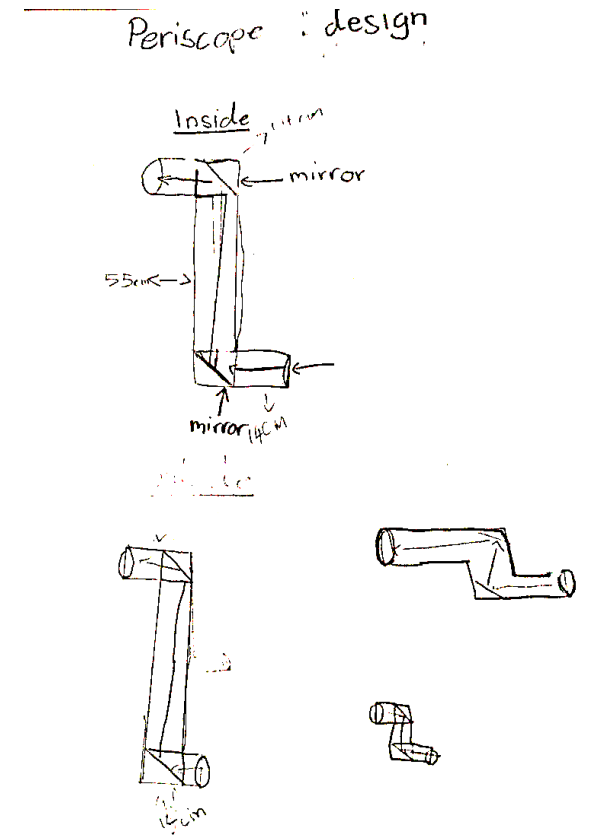
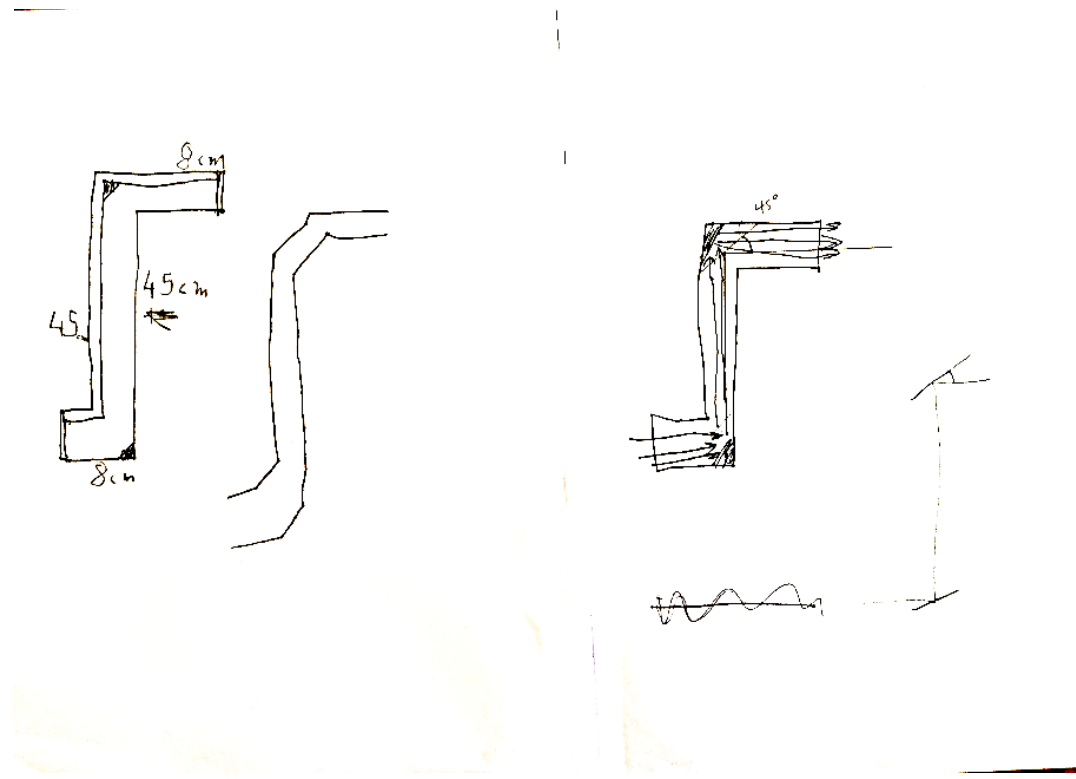

Consolidating	Detailed descriptions of how light travels through different media, using drawings, diagrams, and words.	Full explanations for the object-eyes-light relationship.
---------------	--	---

Focus student: Jack



Pre-test

Pre-test Light

1. For the two situations shown below:
a. Draw arrows to show how light from the sun helps the person to see the tree.



- b. Draw arrows to show how light from the bulb helps the person see the bulb.

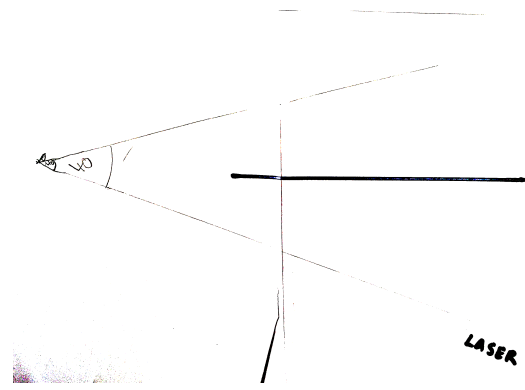

Post-test

POST Light

1. For the two situations shown below:
a. Draw arrows to show how light from the sun helps the person to see the tree.

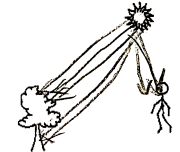

- b. Draw arrows to show how light from the bulb helps the person see the bulb.

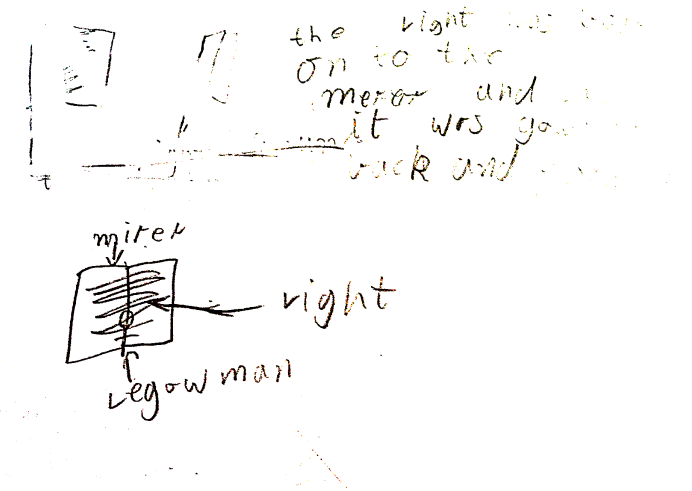
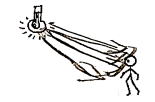

It (light) travels in straight lines and when it hits water it can go in other directions. It bounces off water as well. It can go through paper but not much as it can go through glass.

We put the lazer there and we have to put the mirror somewhere so if its another point on the puzzle. That one against the wall.

Focus student: Charlotte

Pre-test

Post-test

1. For the two situations shown below:
a. Draw arrows to show how light from the sun helps the person to see the tree.

1. For the two situations shown below:
a. Draw arrows to show how light from the sun helps the person to see the tree.

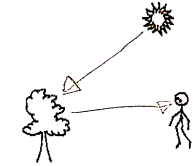
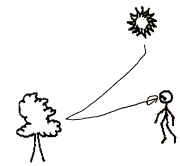

b. Draw arrows to show how light from the bulb helps the person see the bulb.

b. Draw arrows to show how light from the bulb helps the person see the bulb.

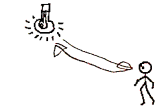
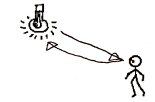

Say there's something in the mirror, if you...because the say the light goes on the mirror then reflects and goes onto your eyes so you can see.

My periscope looks nothing like. It's a box with a wing for the mirror. We had to put mirror in an angle. You look in here and it bounces. It bounces back so you can see out.

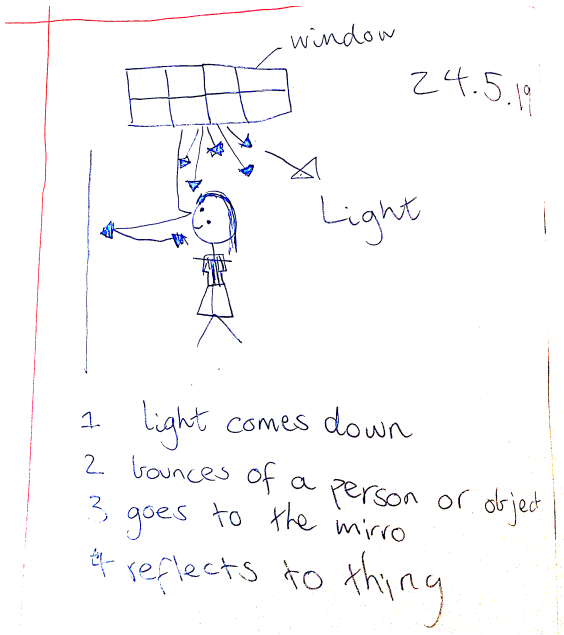

- 1 light comes down
- 2 bounces of a person or object
- 3 goes to the mirro
- 4 reflects to thing

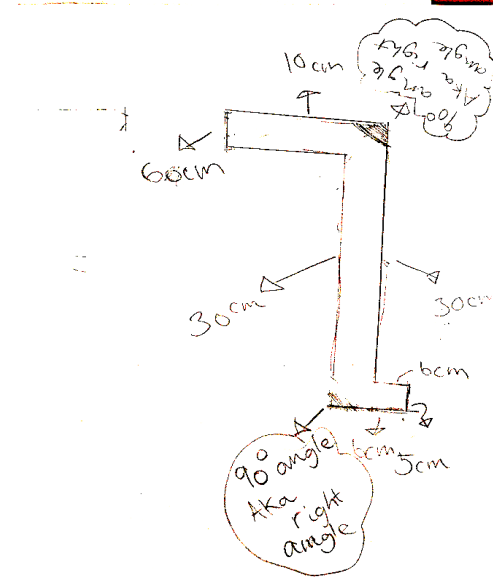
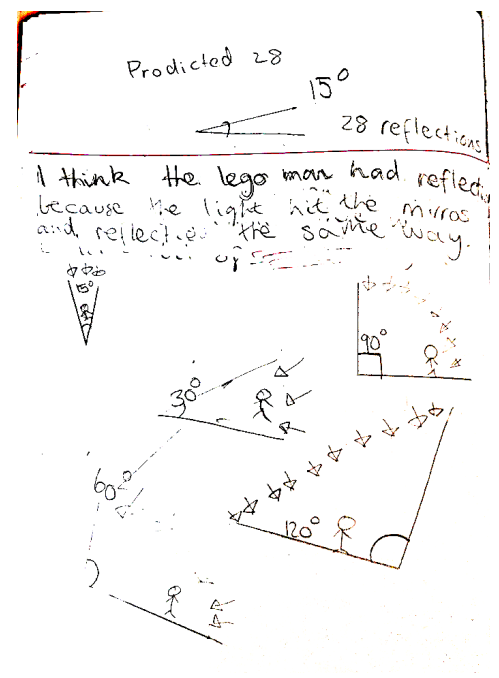

Focus student: Josh



Pre-test

Post-test

We learned that if we learned about light coming out of something, that the light rays drawing you draw arrows of where it's going.

(We worked out) how to find an angle with a protractor. When we were making periscopes, we had to draw a picture and measure how big we wanted it to be. We did how long each side was going to be. We made it 45 on here to make it exact. That's where we got the angle of where the mirror was supposed to be on.

I thought it (periscope) was really cool if you were looking that way, it shows you something different and you can look around corners.

1. For the two situations shown below:
a. Draw arrows to show how light from the sun helps the person to see the tree.

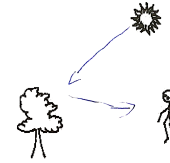

b. Draw arrows to show how light from the bulb helps the person see the bulb.

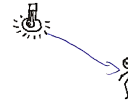

1. For the two situations shown below:
a. Draw arrows to show how light from the sun helps the person to see the tree.

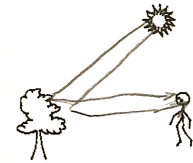

b. Draw arrows to show how light from the bulb helps the person see the bulb.

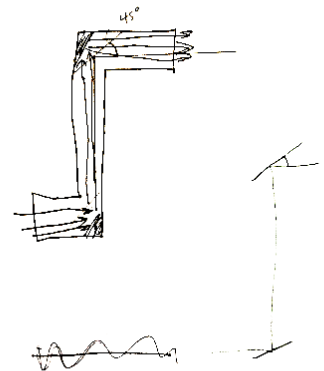
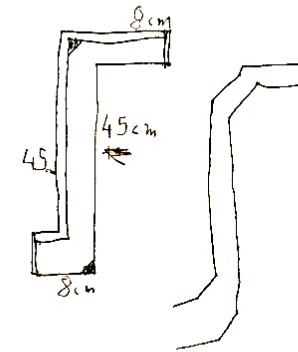
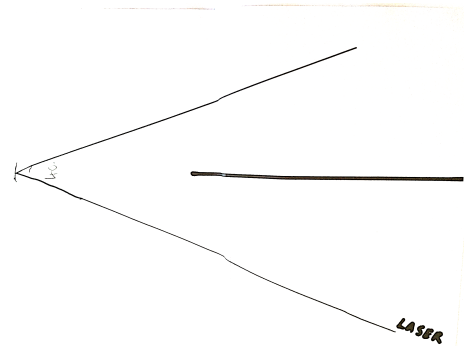
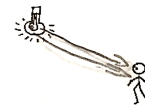

Focus student: Stan

The one rule for light travelling, the incidence angle will be always be the same as the reflected angle. That's the only principle you need to calculate how light travels.

Do it visually. Definitely do it visually. The best way to, it's like a picture story book, I can't really get even though I love books, with a picture story book you can get the image they are really to project, you can see the full thing they want you to do.

Pre-test

1. For the two situations shown below:
a. Draw arrows to show how light from the sun helps the person to see the tree.

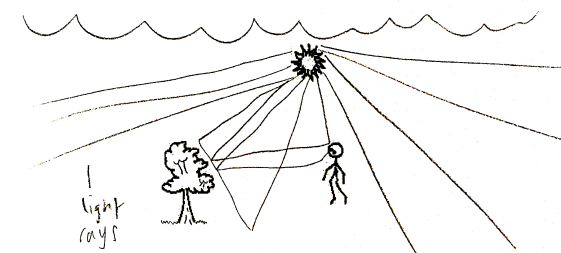

- b. Draw arrows to show how light from the bulb helps the person see the bulb.

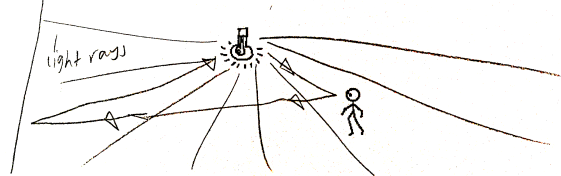

Post-test



1. For the two situations shown below:
a. Draw arrows to show how light from the sun helps the person to see the tree.

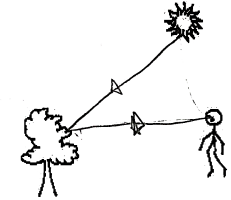

- b. Draw arrows to show how light from the bulb helps the person see the bulb.

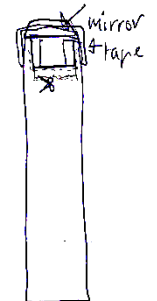
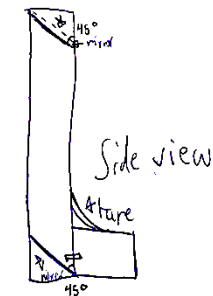
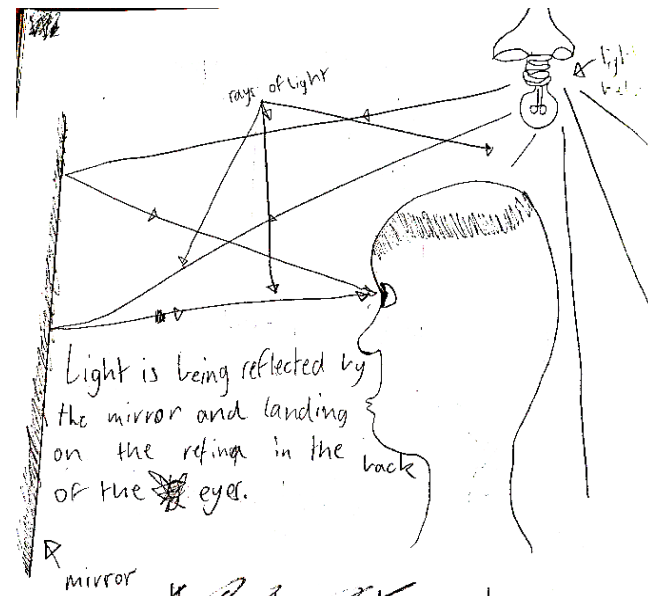
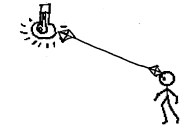

102mm by 147mm

Teacher Perspective: Student understanding



I definitely think they learned a lot, I am not sure if the testing would show that, I do not think it will actually show how much they have learned and I think if they set upon the conversations that **you hear them having and the complex language you hear them using science compared to what it was at the start of the term, or even the year**, so, that has been--

Yes, it's hard to get a measure on that but my own sort of observations and anecdotal notes would suggest that that has really improved by a lot. **Maths wise, I think I look at the maths and go, "Yes, we made links to the maths," but I would love to be able to be teaching them maths at the same time.**

Teacher Perspective: Linking maths with science



I liked the impact of the maths; I like that addition to it. I have run similar units before but never tried to make those links o maths like we did and I particularly liked when we put the Lego men into the shadows and asked the kids to try and where we asked the kids to predict the length, for instance.

I want to say more authentic but it was taking a science concept and saying let us think about the maths that enables us to apply this maths concept. So, it was **not just measurement or graphic or creating a table, it was saying, "All right, we've worked on shadows, we've looked for patterns in the data, how can we now take that understanding and go a little bit further?"** That I really liked and that is something I want to try and do more of.

Whereas thinking about other units I have done there is probably a lot more quantitative data collection where you are thinking the maths is just the fact they are measuring or they are weighing or they are timing, but really thinking about how do we use that in science rather than just a measurement tool.

Teacher Perspective: Student representational competence



Yes, I think, again, looking back to the start of the term, **their whole concept of what a representation is was almost non-existent, they just wanted to write.** Their idea of showing their science understanding was just to write [words].

But I am seeing now ... **the importance of representations that trying to make the kids aware of their thinking or what their thinking is doing and where it's taking them.** They came a long way, they really did. They have got a long way to go still. They have still got a long way to go in terms of ... and I even saw that when I looked over some of these shoulders in the test, how they all went back to just wanting to write rather than saying, "Is there a better way to show this understanding?" Yes, I think it's that idea as well of letting them just get their ideas down but then again, if you had that time to actually then explore their representations more and sit down with them and say, "Well, what were you trying to do here?" I think that is probably a valuable part of the unit.

Successes and Challenges



Successes:

- Learning gains in student use of language
- Value of linking science and mathematics
- Value of visualizing ideas

Challenges:

- Task designs – develop tasks to link maths and science meaningfully
- Assessment – interpret meanings of student generated representations
- Mindset – resort to linguistic means for explanations

For more
information:

lihua.xu@deakin.edu.au

